

(19) World Intellectual Property Organization
International Bureau



(43) International Publication Date
13 February 2003 (13.02.2003)

PCT

(10) International Publication Number
WO 03/012567 A1

(51) International Patent Classification⁷: G05D 23/00,
H05H 1/00, H01L 21/00

(US). FINK, Steven [US/US]; 4609 E. Gable Circle,
Mesa, AZ 85206 (US). JONES, William [US/US]; 934
West Palm Lane, Phoenix, AZ 85007 (US).

(21) International Application Number: PCT/US02/23207

(22) International Filing Date: 19 July 2002 (19.07.2002)

(74) Agents: LAZAR, Dale, S. et al.; Pillsbury Winthrop LLP,
1600 Tysons Boulevard McLean, VA 22102 (US).

(25) Filing Language: English

(26) Publication Language: English

(30) Priority Data:
60/308,447 30 July 2001 (30.07.2001) US

(81) Designated States (*national*): AE, AG, AL, AM, AT, AU,
AZ, BA, BB, BG, BR, BY, BZ, CA, CH, CN, CO, CR, CU,
CZ, DE, DK, DM, DZ, EC, EE, ES, FI, GB, GD, GE, GH,
GM, HR, HU, ID, IL, IN, IS, JP, KE, KG, KP, KR, KZ, LC,
LK, LR, LS, LT, LU, LV, MA, MD, MG, MK, MN, MW,
MX, MZ, NO, NZ, OM, PH, PL, PT, RO, RU, SD, SE, SG,
SI, SK, SL, TJ, TM, TN, TR, TT, TZ, UA, UG, US, UZ,
VN, YU, ZA, ZM, ZW.

(71) Applicant (*for all designated States except US*): TOKYO
ELECTRON LIMITED [JP/JP]; TBS Broadcast Center,
3-6, Akasaka 5-chome, Minato-ku, Tokyo 107 (JP).

(72) Inventors; and

(75) Inventors/Applicants (*for US only*): MITROVIC, An-
drej [YU/US]; 14435 S. 48th Street, #1203, Phoenix, AZ
85044 (US). LONG, Maolin [CN/CN]; Fujin Road No.3,
Building 2, Room 904, Guangzhou (CN). MOROZ, Paul
[US/US]; 2714 E. Amberwood Drive, Phoenix, AZ 85048

(84) Designated States (*regional*): ARIPO patent (GH, GM,
KE, LS, MW, MZ, SD, SI, SZ, TZ, UG, ZM, ZW),
Eurasian patent (AM, AZ, BY, KG, KZ, MD, RU, TJ, TM),
European patent (AT, BE, BG, CH, CY, CZ, DE, DK, EE,
ES, FI, FR, GB, GR, IE, IT, LU, MC, NL, PT, SE, SK,
TR), OAPI patent (BF, BJ, CF, CG, CI, CM, GA, GN, GQ,
GW, ML, MR, NE, SN, TD, TG).

[Continued on next page]

(54) Title: PLASMA CHAMBER WALL SEGMENT TEMPERATURE CONTROL

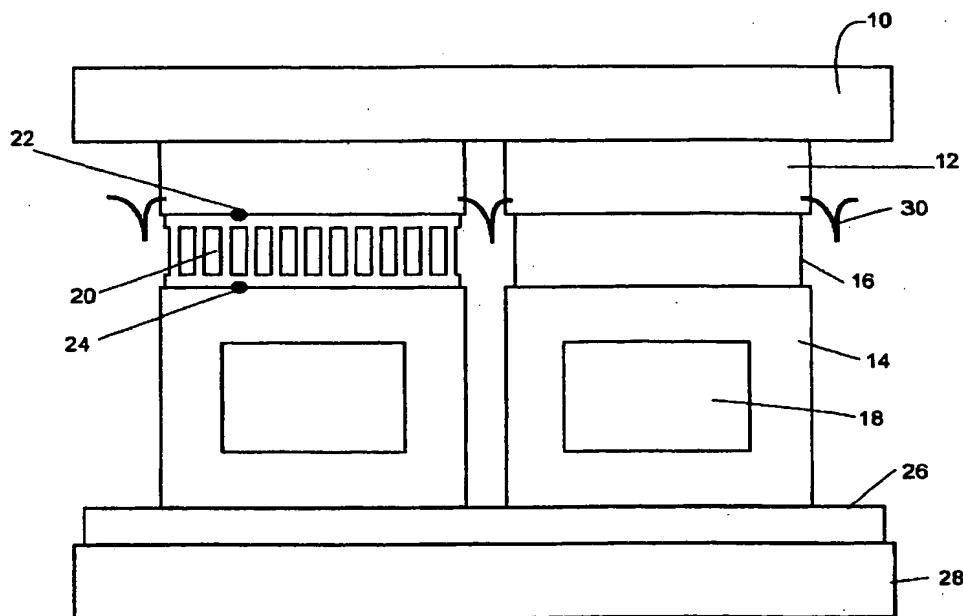

(57) Abstract: A device and method for controlling the temperature of a plasma chamber inside wall or other surfaces exposed to the plasma by a plurality of temperature control systems. A plasma process within the plasma chamber can be controlled by independently controlling the temperature of segments of the wall or other surfaces.



WO 03/012567 A1

WO 03/012567 A1



Published:
with international search report

For two-letter codes and other abbreviations, refer to the "Guidance Notes on Codes and Abbreviations" appearing at the beginning of each regular issue of the PCT Gazette.

PLASMA CHAMBER WALL SEGMENT TEMPERATURE CONTROL

[0001] This application is based on and derives benefit from U.S. Provisional Patent Application No. 60/308,447, filed July 30, 2001, the entire contents of which are incorporated herein by reference.

BACKGROUND OF THE INVENTION

1. Field of the Invention

[0002] The invention relates in general to plasma chambers and, more particularly, to a plasma chamber that has a wall temperature control system.

2. Description of Related Art

[0003] Plasma chambers may be used to contain plasma, for example, in a plasma semiconductor substrate processing tool. Typically, plasma ions are accelerated toward a semiconductor substrate within the plasma chamber. During the course of the process, ions, neutral particles, and contaminants are pumped out of the chamber while fresh gas is supplied and formed into plasma.

[0004] The chamber wall temperature affects the local surface chemistry, e.g. the nature and amounts of different chemical species adsorbed and emitted from the walls. These species in turn affect the local gas phase chemistry in the plasma, and thus the plasma process result, e.g. rate, selectivity, etc.

[0005] With the current trend of introducing in-situ chamber cleaning steps between wafer batches, fast ramp-up and ramp-down of wall temperatures can be advantageous.

SUMMARY OF THE INVENTION

[0006] The present invention provides an apparatus and a method of independently controlling the temperature of different segments of the plasma chamber inside wall, and/or other surfaces exposed to the chamber plasma. The temperature of segments of the plasma chamber inside walls and other surfaces are independently controlled by a plurality of temperature control systems.

BRIEF DESCRIPTION OF THE DRAWINGS

[0007] FIG. 1 is a schematic representation of two segments of the plasma chamber wall temperature control system;

[0008] FIG. 2 is a graph showing a temperature distribution along the chamber wall of FIG. 1;

[0009] FIG. 3 is a schematic representation of a fluid circulation system used to feed cooling or heating fluid to the plasma chamber wall temperature control segments;

[0010] FIG. 4 is a schematic representation of a fluid circulation system used to feed cooling fluid to the plasma chamber wall temperature control segments.

[0011] FIG. 5 is an overhead view of a plasma chamber utilizing the plasma chamber wall temperature control system illustrated in FIG. 1;

DETAILED DESCRIPTION OF THE EMBODIMENTS

[0012] FIG. 1 shows the structure of two segments of the plasma wall temperature control system. The inside of the plasma chamber is defined by a plasma chamber inside wall, indicated at 10. At least an inner portion of the plasma chamber inside wall 10 may be made of a ceramic-type material, which typically has a low thermal conductivity, such as quartz, alumina, yttria, etc. Materials of low thermal conductivity allow improved independent temperature control of various segments of the plasma chamber inside wall 10. Materials with a higher thermal conductivity, such as anodized aluminum, stainless steel, or the like can also be used.

[0013] A thermal conductor, indicated at 12, is seated in thermal contact with the back side of a segment of the plasma chamber inside wall 10. The thermal conductor 12 may be made of a material with a high thermal conductivity, for example a metal such as aluminum. The left and right segments of the plasma wall temperature control system shown in FIG. 1 each contain a thermal conductor 12. Each thermal conductor 12 controls the temperature of a segment of the plasma chamber inside wall 10. Each thermal conductor 12 is in direct contact with either a thermoelectric device, indicated at 20, or a "dummy" insert, indicated at 16. Referring to the left segment, the thermal conductor 12 is in direct contact with the thermoelectric device 20. Referring to the right segment, the thermal conductor 12 is in direct contact with a dummy insert 16. The dummy insert 16 in the segment of the plasma wall temperature control system without

the thermoelectric device 20 mimics the thermal properties, e.g. nominal heat conductance, of the thermoelectric device 20.

[0014] Referring to the right segment of FIG. 1, the dummy insert 16 is in direct contact with a temperature controlling block, indicated at 14. Temperature controlling block 14 has a conduit, indicated at 18, to carry a fluid. For those segments that contain a thermoelectric device 20, the thermoelectric device 20 is in direct contact with the temperature controlling block 14. The fluid in the conduit 18 of the temperature controlling block 14 can either heat or cool the segment of the plasma chamber inside wall 10, depending on the fluid temperature. Heating or cooling is by direct thermal conduction, from the fluid to the segment of the plasma chamber inside wall 10, via the conduit 18 of the temperature controlling block 14, dummy insert 16 or thermoelectric device 20, and thermal conductor 12. The thermoelectric device 20 can allow higher precision and generally faster response temperature control of the segment of the plasma chamber inside wall 10, by varying the current and voltage supplied to the thermoelectric device 20 by a variable DC power source (not illustrated).

[0015] Thermocouples 22 and 24 determine the temperatures on both sides of the thermoelectric device 20. The thermoelectric device 20 can be disconnected from the DC power source so that the voltage and current into the known load of the thermoelectric device 20 can be used to determine the heat flow through it. Heat flow information can be used for plasma chamber process control. If higher resolution temperature control is required, all temperature control segments may have thermoelectric devices 20 installed. If only measurement of heat flow is required, not all temperature control segments may have thermoelectric devices 20 installed.

[0016] A layer of heat insulation material, indicated at 26, prevents heat exchange between temperature controlling blocks 14 via the plasma chamber outside wall, indicated at 28. Segments of the plasma wall temperature control system are spaced apart so that they do not touch each other, preventing heat exchange via direct thermal conduction. The insulation 26 acts to hold the temperature control systems against the outside surface of chamber inside wall 10. If other means of holding temperature control systems against wall 10 are used, insulators 26 may be omitted, and the gas that fills the space between walls 10 and 28 then provides the insulation.

[0017] RF shielding of the plasma chamber may be included, depending on the type of plasma generator used. A thin metal foil, indicated at 30, bridges the space between the thermal

conductors 12. Heat exchange between conductors 12 is minimized because the foil 30 is thin. The foil 30 completes an electrically continuous RF energy shield around the plasma chamber.

[0018] FIG. 2 shows a graph exemplifying an achievable temperature distribution along the plasma chamber inside wall 10. The sharp temperature step, indicated at 40, between the two segments of the plasma chamber inside wall 10, is partly achievable due to the low thermal conductivity of the material, partly due to small thickness of the plasma chamber inside wall 10.

[0019] FIG. 3 shows a fluid circulation system used to supply heating or cooling fluid to the conduits 18 of the temperature controlling blocks 14 of the plasma wall temperature control system. Two high-flow fluid sources can be used. A higher-temperature fluid source, indicated at 50, provides a fluid of as high or higher temperature than the highest required temperature of any plasma chamber process. A lower-temperature fluid source, indicated at 52, provides a fluid of as low or lower temperature than the lowest required temperature of any plasma chamber process.

[0020] A selector valve, indicated at 54, selectively sends either higher-temperature or lower-temperature fluid to the conduit 18. Varying which fluid is sent allows control of the temperature of the plasma chamber inside wall 10. The selector valves 54 and 56 are located near the conduits 18, reducing the amount of fluid needing replacement when a temperature change is needed.

[0021] The thermoelectric devices 20 provide higher precision temperature control, and can sustain a temperature difference of, for example, a few tens of degrees. The temperature difference can compensate for a fluid that does not yet have the exact desired temperature necessary for the plasma chamber process. The thermoelectric devices are provided with varying current and voltage to compensate for or sustain any temperature differences required for wall segment temperature control. The thermoelectric devices are also able to adjust their temperatures more rapidly than the fluid system.

[0022] If a fluid source 50 or 52 is not in use, it may be put in a bypass position via a relief valve, indicated at 58. The bypassed fluid circulates through the fluid circulation system, always ready for the next temperature change. In another embodiment, the selector valve 54 may be a liquid mixing valve, allowing selective combination of the heating and cooling fluids to set the fluid at a desired temperature for steady state conditions, or heating only or cooling only, for quick heating or cooling. A further embodiment eliminates the heating fluid 50 and selector valves 54 and 56 from the fluid circulation system by using resistive heaters (which may

also be the same device as the thermoelectric device 20) for heating. FIG. 4 shows the simplified cooling fluid circulation system. On-off valves (which may also be the same valve as the relief valve 58) can be used in the simplified cooling fluid circulation system. This embodiment can provide a highly controlled heat-up process, via current and voltage supplied to the resistive heater.

[0023] The temperature and heat flow measured by the thermocouples 22, 24 and the thermoelectric devices 20 can be used in a feedback control system to maintain a desired plasma chamber inside wall temperature over each segment of the chamber wall 10. The temperature and heat flow can also be used to monitor the plasma process being carried out in the plasma chamber. Plasma processing can be controlled based on the feedback from the temperature and heat flow information. The temperature of a portion of the wall can be measured and correlated to parameters of the plasma process. The parameters of the plasma process can then be adjusted as necessary by adjusting the temperature control systems. FIG. 5 shows the segments of the plasma wall temperature control system arranged to surround the plasma chamber 60.

[0024] The wall temperature distribution can be correlated to the process properties, such as etch rate, selectivity, device damage, repeatability, etc., via a design-of-experiments (DOE) approach, in which a large number of tests are made, so that a meaningful correlation is obtained. This correlation may be programmed in the form of a look-up table database in the tool controller. Then, during a process, when a temperature distribution on the wall is known from measurements at each individual segment, an estimate of the achievable process results can be obtained using various methods known in the art. If this uniformity is not satisfactory, then a control signal is sent to all segments to adjust their temperatures to a setpoint where the desired process results are obtained, in combination, of course, with other operating parameters of the current process in the tool. With all segments individually controllable, one can also achieve azimuthal process results control. The heat flux information is useful for quantifying the plasma bombardment of the wall. A high heat flux means that the wall is subjected to a high ion bombardment flux, which invariably causes sputtering of the wall material. This can contaminate the process and reduce the lifetime of the chamber wall, increasing costs. If a particularly "clean" process needs to be achieved, then the heat flux information can be used to adjust process parameters so that wall bombardment is minimized.

[0025] Likewise, the system may be used, for example, to reduce the time necessary between process steps. For example, between wafers, the chamber may be cleaned at a

temperature higher than the wafer process. The system according to the present invention allows rapid chamber heating so that throughput may be increased.

[0026] The same segmented temperature control system may be used on the substrate holder assembly, the gas injection plate, and in other locations in the chamber where precise wall temperature control is required for good process results.

[0027] It will thus be seen that the objects of this invention have been fully and effectively accomplished. It will be realized, however, that the foregoing preferred specific embodiments have been shown and described for the purpose of illustrating the functional and structural principles of this invention and are subject to change without departure from such principles. Therefore, this invention includes all modifications encompassed within the spirit and scope of the following claims.

What is claimed is:

1. A method of controlling a temperature of a plasma chamber wall comprising:
controlling the temperature of a plurality of segments of the wall or other surfaces exposed to the plasma with a plurality of temperature control systems of a first type; and
controlling the temperature of a plurality of segments of the wall or the other surfaces with a plurality of temperature control systems of a second type different from the first type.
2. A method as in claim 1 wherein the second type of control system has a faster thermal response than the first type of control system.
3. A method as in claim 1, wherein the second type of control system has a higher resolution thermal response than the first type of control system.
4. A method as in claim 1 further comprising measuring the temperature of at least a portion of the wall or the other surfaces with the temperature control system of the second type.
5. A method as in claim 1 wherein the temperature control systems of the first type comprise fluid circulation systems.
6. A method as in claim 1 wherein the temperature control systems of the second type comprise thermoelectric devices.
7. A method as in claim 6 further comprising measuring heat flux using the thermoelectric devices.
8. A method as in claim 7 further comprising correlating the measured heat flux to values in a look-up table to obtain an estimated process parameter and;
adjusting at least one of the temperature control systems of a first type and the temperature control systems of a second type based on the estimated process parameter.
9. A method as in claim 8 wherein the process parameter is uniformity.
10. A method as in claim 1 further comprising comparing a measured temperature distribution to values stored in a look-up table to determine process uniformity.
11. A method as in claim 10 wherein the look-up table is provided through a design-of-experiments approach.
12. A method as in claim 1 further comprising:

measuring the temperature of at least a portion of the wall or other surfaces; and
using the measured temperature of the wall or other surfaces to control the temperature control systems.

13. A plasma chamber temperature control, for use with a plasma chamber having a wall or other surfaces exposed to the plasma, comprising:

a plurality of temperature control systems of a first type in thermal communication with the plasma chamber wall or the other surfaces; and

a plurality of temperature control systems of a second type different from the first type disposed in thermal communication with the plasma chamber wall or the other surfaces.

14. A plasma chamber temperature control as in claim 13, wherein the second type of control systems include thermoelectric devices, disposed between at least selected ones of the temperature control systems of the first type and the plasma chamber wall or the other surfaces.

15. A plasma chamber temperature control as in claim 13, wherein the first type of temperature control systems include temperature controlling blocks.

16. A plasma chamber temperature control as in claim 15, wherein the temperature controlling blocks are thermally insulated from each other.

17. A plasma chamber temperature control as in claim 15, wherein each temperature controlling block has a conduit therethrough.

18. A plasma chamber temperature control as in claim 13, further comprising a fluid supply in fluid communication with the temperature control systems of the first type to enable circulation of a fluid therethrough.

19. A plasma chamber temperature control as in claim 18, wherein the temperature control system further comprises a heater to enable heating of the fluid, and a relatively colder fluid supply, and a valve, the valve being selectively operable to allow selective fluid flow from at least one of the fluid supply and the colder fluid supply.

20. A plasma chamber temperature control as in claim 19, wherein the heaters are electrically controllable.

21. A plasma chamber temperature control as in claim 18, wherein the fluid supply further comprises a relatively hotter fluid supply and a relatively colder fluid supply, and a

valve, the valve being selectively operable to allow fluid flow from one of the hotter fluid supply and the colder fluid supply.

22. A plasma chamber temperature control as in claim 21, wherein the valve is further selectively operable to allow fluid flow from a combination of the hotter fluid supply and the colder fluid supply.

23. A method of controlling a plasma process comprising:

processing a substrate with a plasma within a plasma chamber having a wall or other surfaces exposed to the plasma;

controlling the temperature of a plurality of segments of the wall or the other surfaces with a plurality of temperature control systems of a first type;

controlling the temperature of a plurality of segments of the wall or the other surfaces with a plurality of temperature control systems of a second type different from the first type;

measuring the temperature of at least a portion of the wall or the other surfaces;

adjusting a parameter of the plasma process by adjusting the temperature control systems.

24. A method as in claim 23, wherein the second type of temperature control systems have a faster thermal response than the first type of temperature control systems.

25. A method as in claim 23, wherein the second type of temperature control systems have a higher resolution thermal response than the first type of temperature control systems.

26. A method as in claim 23, wherein the measuring is performed using at least one of the temperature control systems of the second type.

27. A plasma chamber comprising:

a chamber having a wall or other surfaces exposed to the plasma;

a plurality of temperature controlling blocks disposed in thermal communication with the plasma chamber wall or the other surfaces, each temperature controlling block having a conduit therethrough;

a plurality of thermoelectric devices, disposed between at least selected ones of the temperature controlling blocks and the plasma chamber wall or the other surfaces; and

a fluid supply in fluid communication with the conduits to enable circulation of a fluid therethrough.

28. A plasma chamber as in claim 27, wherein the temperature controlling blocks are thermally insulated from each other.

29. A plasma chamber as in claim 27, wherein the temperature controlling blocks are disposed outside of the plasma chamber.

30. A plasma chamber temperature control, for use with a plasma chamber having a wall or other surfaces exposed to the plasma, comprising:

a plurality of temperature control systems disposed in thermal communication with the plasma chamber wall or the other surfaces, each temperature control system being independently controllable.

31. A method of controlling a plasma process comprising:

independently controlling the temperature of a plurality of segments of the plasma chamber wall or other surfaces exposed to the plasma.

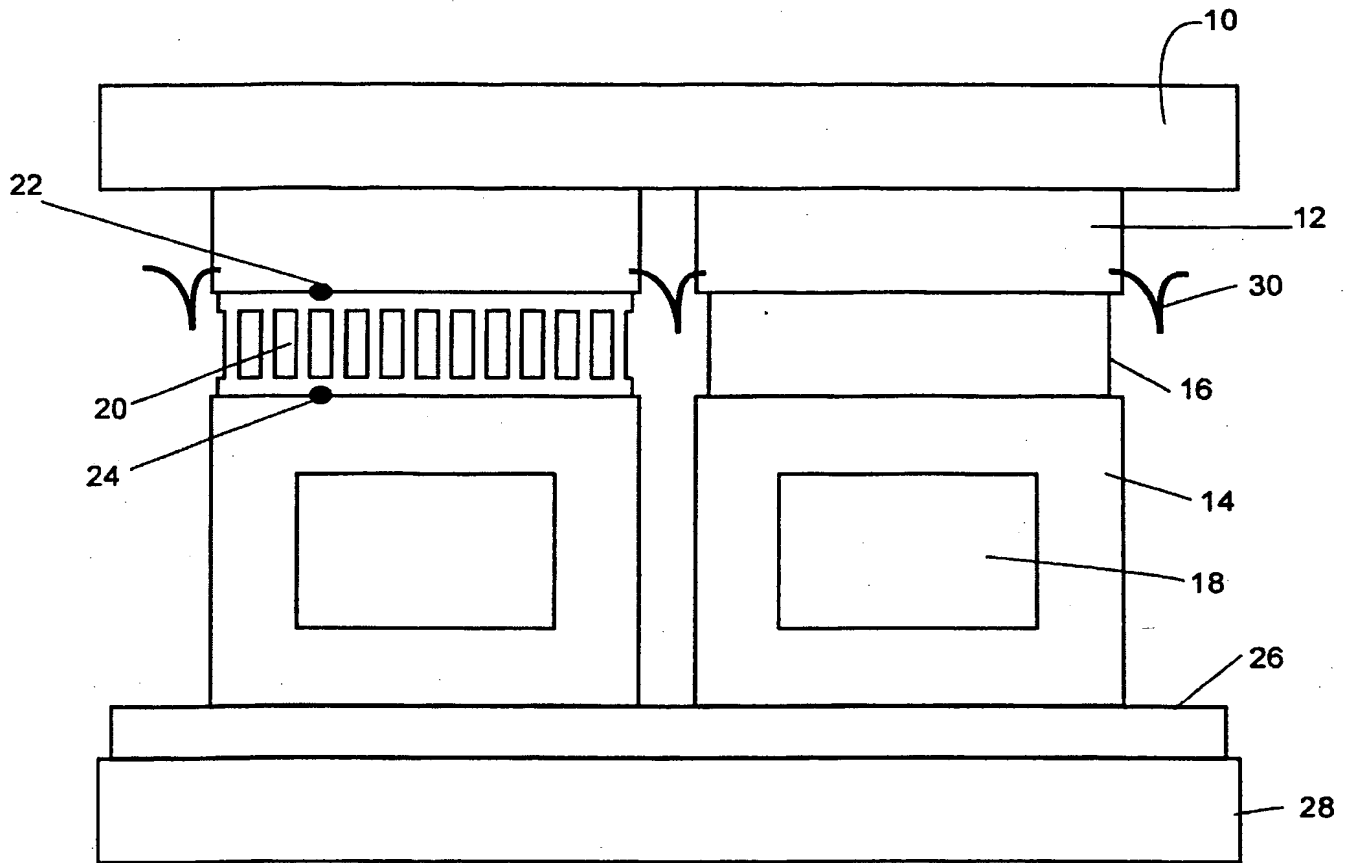

FIG. 1

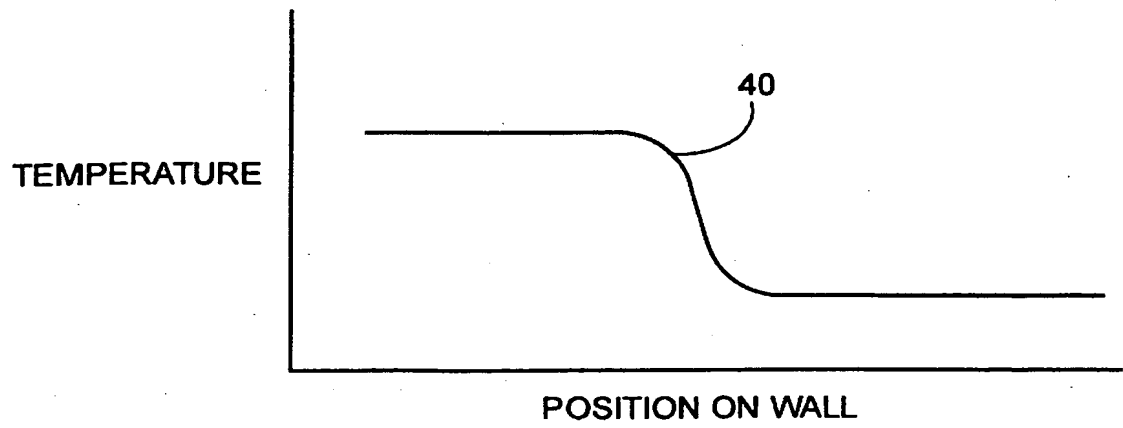

FIG. 2

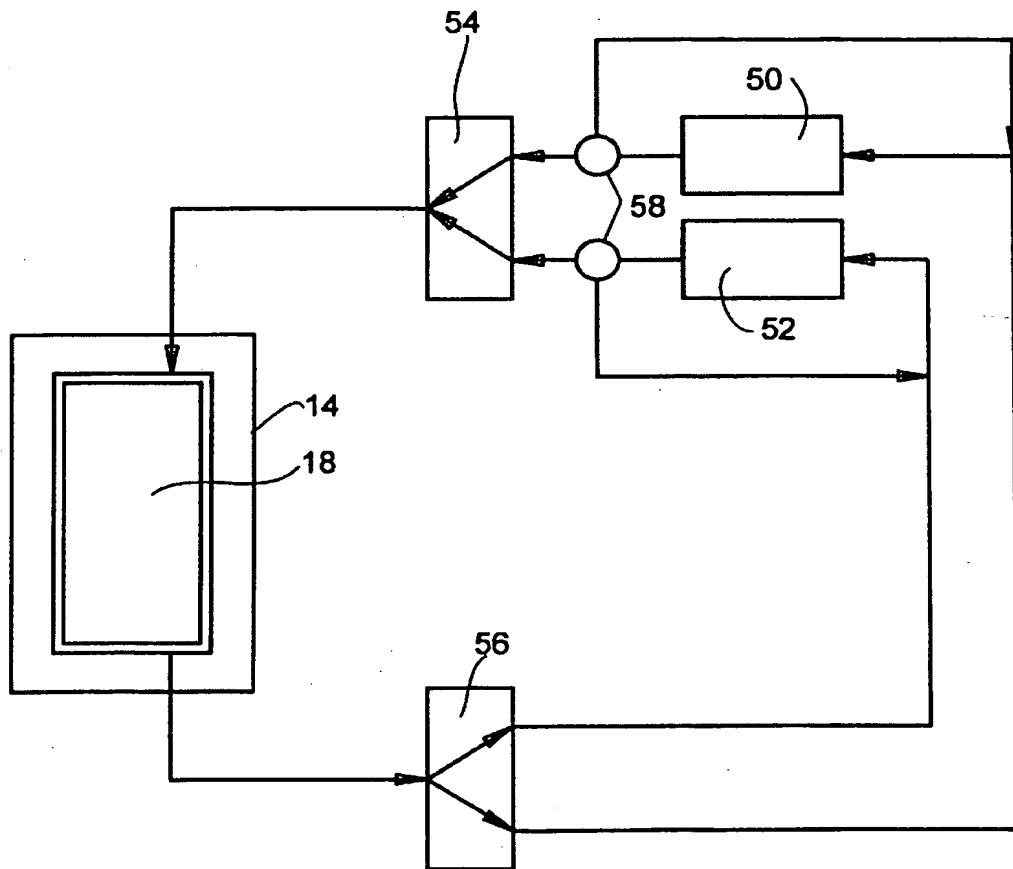

FIG. 3

4/5

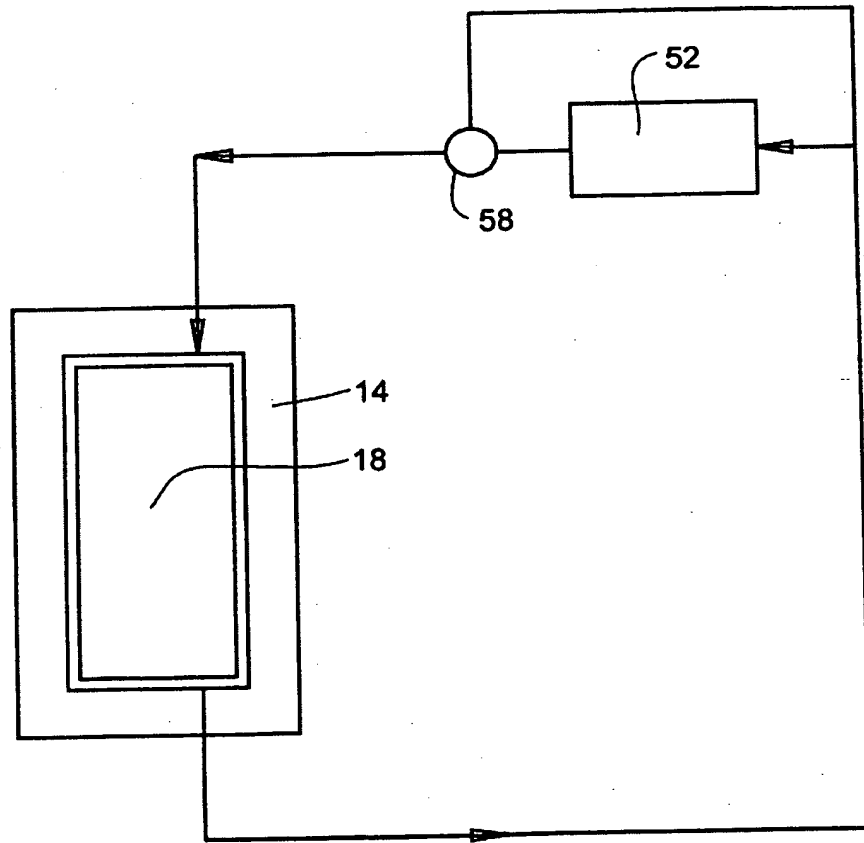

FIG. 4

5/5

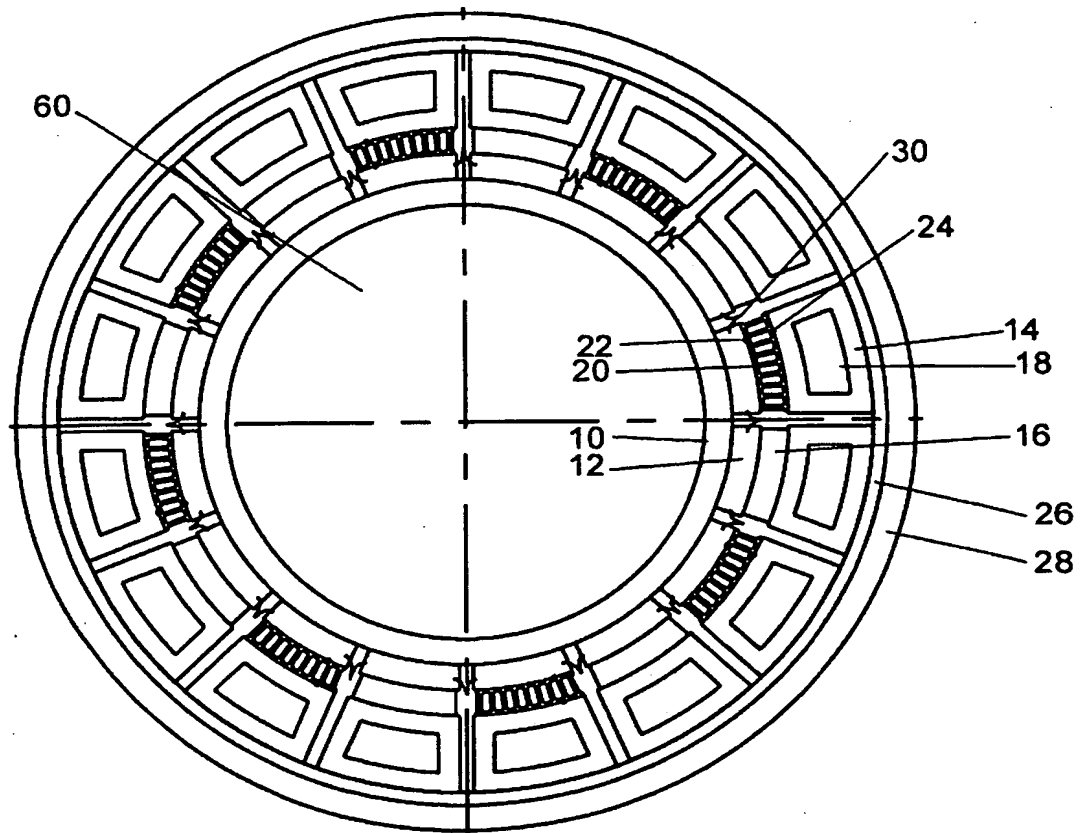

FIG. 5

INTERNATIONAL SEARCH REPORT

International Application No
PCT/US 02/23207

A. CLASSIFICATION OF SUBJECT MATTER
IPC 7 G05D23/00 H05H1/00 H01L21/00

According to International Patent Classification (IPC) or to both national classification and IPC

B. FIELDS SEARCHED

Minimum documentation searched (classification system followed by classification symbols)
IPC 7 G05D H05H H01L

Documentation searched other than minimum documentation to the extent that such documents are included in the fields searched

Electronic data base consulted during the international search (name of data base and, where practical, search terms used)
EPO-Internal, WPI Data, PAJ

C. DOCUMENTS CONSIDERED TO BE RELEVANT

Category *	Citation of document, with indication, where appropriate, of the relevant passages	Relevant to claim No.
X	EP 0 838 841 A (APPLIED MATERIALS INC) 29 April 1998 (1998-04-29)	27, 29
Y	column 16, line 3 -column 17, line 23 column 22, line 36 -column 24, line 53 column 26, line 39 -column 28, line 56 column 30, line 20 -column 30, line 23; figures 10-13,17,18,24	1-15,17, 18,23-25
X	WO 99 25494 A (TOKYO ELECTRON LTD ; JOHNSON WAYNE L (US)) 27 May 1999 (1999-05-27)	30, 31
Y	page 11, line 4 -page 11, line 8 page 12, line 9 -page 13, line 13; figures 1E,2,3A	1-15,17, 18

Further documents are listed in the continuation of box C. Patent family members are listed in annex.

* Special categories of cited documents :

A document defining the general state of the art which is not considered to be of particular relevance

E earlier document but published on or after the international filing date

L document which may throw doubts on priority claim(s) or which is cited to establish the publication date of another citation or other special reason (as specified)

O document referring to an oral disclosure, use, exhibition or other means

P document published prior to the international filing date but later than the priority date claimed

T later document published after the international filing date or priority date and not in conflict with the application but cited to understand the principle or theory underlying the invention

X document of particular relevance; the claimed invention cannot be considered novel or cannot be considered to involve an inventive step when the document is taken alone

Y document of particular relevance; the claimed invention cannot be considered to involve an inventive step when the document is combined with one or more other such documents, such combination being obvious to a person skilled in the art.

* & * document member of the same patent family

Date of the actual completion of the international search 27 September 2002	Date of mailing of the international search report 15/10/2002
--	--

Name and mailing address of the ISA European Patent Office, P.B. 5818 Patentlaan 2 NL - 2280 HV Rijswijk Tel. (+31-70) 340-2040, Tx. 31 651 epo nl, Fax: (+31-70) 340-3016	Authorized officer Henrikson, O
--	--

INTERNATIONAL SEARCH REPORT

national Application No
PCT/US 02/23207

C.(Continuation) DOCUMENTS CONSIDERED TO BE RELEVANT

Category *	Citation of document, with indication, where appropriate, of the relevant passages	Relevant to claim No.
Y	US 6 113 732 A (YOSHIDA KOHEI ET AL) 5 September 2000 (2000-09-05) abstract; figures 1,2 column 7, line 38 -column 7, line 67 -----	1-15,17, 18,23-25

INTERNATIONAL SEARCH REPORT
Information on patent family members

International Application No

PCT/US 02/23207

Patent document cited in search report		Publication date	Patent family member(s)	Publication date
EP 0838841	A	29-04-1998	US 6308654 B1	30-10-2001
			EP 0838841 A2	29-04-1998
			JP 10149899 A	02-06-1998

WO 9925494	A	27-05-1999	CN 1278750 T	03-01-2001
			EP 1030745 A1	30-08-2000
			JP 2001523887 T	27-11-2001
			WO 9925494 A1	27-05-1999
			US 6425953 B1	30-07-2002

US 6113732	A	05-09-2000	JP 9256162 A	30-09-1997
